

Improving performance of existing deep foundations

A. M. McNamara

Senior Lecturer, Department of Civil Engineering, City, University of London, London, United Kingdom

J. P. Panchal

Technical Manager, Keltbray Ltd, London, United Kingdom

G. Sabaliauskaite

Research Student, Department of Civil Engineering, City, University of London, London, United Kingdom

M. Ucur

Research Student, Department of Civil Engineering, City, University of London, London, United Kingdom

ABSTRACT

Increasingly, redevelopment of construction sites in London and many other large cities involves developing solutions for enabling reuse of existing deep foundations. New developments tend to be larger (taller) than the previous development and column spacings are usually greater as well. This means that the challenge to foundation reuse is that the required load bearing capacity is increased and concentrated across fewer positions on the site. Consequently, any means of improving individual or group pile capacity could be beneficial to the overall foundations scheme to promote the further adoption of pile reuse.

This research describes some preliminary work that has been undertaken considering the impact of steel sheet piles installed around a single existing bored pile, thus creating a composite foundation. Centrifuge model testing has been used to explore the behaviour of a single bored pile with and without enhancement in the form of sheet piles surrounding an existing centrally positioned bored pile. The paper gives background and context to the problem and describes the experimental process and load-displacement comparisons, giving insight into the use of this method of capacity enhancement and recommendations for further work.

Key words: *Piled foundation, Sheet pile, Foundation reuse, Composite foundation*

1. Outline of the project

1.1. London Geotechnical Centrifuge Centre, City, University of London

The research was carried out at the London Geotechnical Centrifuge Centre which is located at City, University of London. The facility contains an Acutronic 661 beam centrifuge which is a 40g tonne machine; capable of accelerating a 200kg package to a maximum of 200g. The characteristics of the machine are described in detail by Schofield and Taylor (1988). The experimental work described was carried out at an acceleration of 50g; and with a package weight of about 150kg was well within

the capacity of the machine

1.2. Background and objectives of the project

Piled foundations have been used extensively for about the last 60 years and most large cities are beginning to experience the problems inherent in dealing with reuse of existing deep foundations. Until relatively recently each new generation of a development on a particular site would be supported on new foundations. This has led to a situation where multiple sets of existing foundations create deep obstructions that are costly and time consuming to remove if they clash with the specified

locations of new foundations. This is increasingly common given that many sites are now on their third generation of deep foundations. The climate crisis has led to increased scrutiny over the use of materials in construction and there is now a well-established attitude about the need to drastically reduce the use of concrete.

Despite the previous proof of integrity and subsequent soil consolidation that will have occurred around existing foundations, often their capacity cannot be proven or justified as being capable of carrying the increased loads of taller mixed-used development buildings. In view of this there is merit in exploring processes for enhancing the capacity of existing foundations to accommodate such additional loads.

The aim of this paper is to describe the process of some model testing and comment on the experimental results, which explore the capacity of a composite foundation consisting of a central bored pile; representing an existing foundation that may be found on a redevelopment site. The pre-existing pile has had its capacity enhanced by the provision of sheet piles pressed into the soil around the pile such that the elements can be combined into a single load bearing element by the provision of a cast pile cap. The capacity of this enhanced foundation will be compared against a traditional bored pile to provide a normalized load bearing capacity.

Whilst steel sheet piles and bored concrete piles are commonly used on a single development site where an excavation is required, the use of the two foundation types are not interlinked, and instead is typically limited to using sheet piles as a retaining structure, whilst the bored piles provide bearing resistance to the superstructure. The use of a composite piled structure comprising a sheet piled wall surrounding individual bored piles, as described in this paper is novel.

2. Structural sites and piling method

2.1. Site condition

In the 1960's early bored cast in-situ piles tended to be between 450mm and 600mm diameter ranging between 12m and 15m in length. Multiple piles were used, combined with a pile cap, to create a foundation capable of carrying the applied load. These foundations are not especially problematic for future developments since

modern equipment can bore through them provided their presence is known.

During the 1970's larger piles could be constructed (Figure 1) using hydraulic piling rigs capable of diameters up to 2m and more; sometimes with enlarged bases to gain additional bearing capacity at the toe. Dealing with these deep obstructions is extremely costly and time-consuming and complete removal of such piles is essentially impossible; it is often necessary to avoid both the shaft and enlarged bases when developing a layout for new foundations.



Figure 1 Typical large diameter pile on a redevelopment site

2.2. Model ground condition

The Speswhite Kaolin clay used in the tests was prepared from slurry with an initial water content of approximately 120%; which is twice the liquid limit. The slurry was created by mixing dry powder and distilled water in an industrial ribbon blade mixer. The inside faces of the model container were coated with water pump grease to minimise friction at the boundaries. The slurry was carefully placed into the model container and manually agitated to expel the most of the air bubbles. Beneath the slurry there was a filter paper and a 3mm porous plastic sheet, with an aluminium drainage plate at the base. On top of the slurry, a second filter paper and porous plastic sheet were placed and drainage was allowed through holes in a loading platen. Consolidation was achieved by means of a hydraulic press over a period of seven days including one day of swelling. The samples were compressed to a vertical stress of 400kPa that was then reduced to 200kPa creating a homogenous sample with an undrained shear strength of around 40kN/m²

2.3. Centrifuge model making

The centrifuge model was prepared on the laboratory bench at 1g. The soil sample was removed from the consolidation press and the top trimmed using a purpose made cutter to reduce the clay (Figure 2). to a predetermined level that would permit the use of the custom-made loading apparatus.

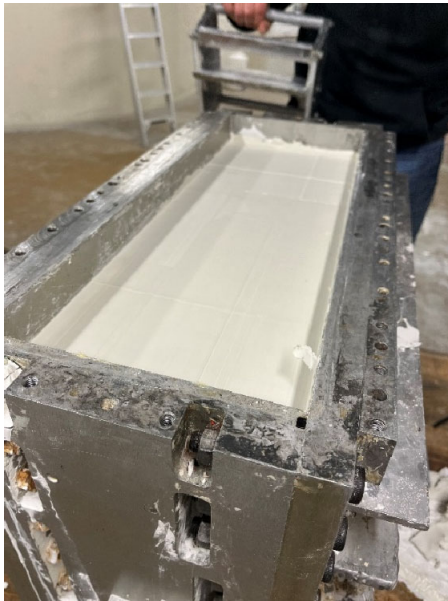

Figure 2 Trimming the clay surface to the correct level

A Perspex template as shown in Figure 3, was positioned on the clay surface. The template had spigot guides that permitted the position of the pile bores to be marked in precise locations.



Figure 3 Method of positioning piles.

The top surface of the clay was sealed with a product known commercially as PlastiDip, a multipurpose synthetic rubber coating that is available in many colours. The aerosol spray applied membrane adheres to the top of the clay and once dried (3–4 min) can be cut with a scalpel. The cured membrane is typically 400µm thick as shown in Figure 4 (McNamara and Gorasia 2016). This material prevents degradation of the soil caused by drying on the laboratory bench and also in flight on the centrifuge but possesses negligible strength and therefore deforms with the soil.



Figure 4 Method of sealing the surface of the clay model

2.4. Rotary bored pile installation

A total of three piled foundation models were installed in the 550mm x 200mm strong box as part of this experiment. The foundation models were positioned equidistant from one another, with sufficient distance to the walls of the model container to minimize the influence of edge distance effects.

The diameter of the model existing rotary bored piles was 16mm, representative of a 0.8m diameter pile at prototype scale. The aluminium piles were abraded to create a roughened finish to provide soil/pile interface friction that would be reasonably representative of that created with a concrete bored pile.

Each pile bore was excavated using a thin walled stainless steel tube cutter that was inserted through the spigot guides and gently rotated when embedded to each pile base level thereby ensuring that a complete plug of soil was effectively sheared. When bores for all three piles had been made the jig was removed and the solid aluminium model piles were inserted into each empty pile

bore. The weight of the piles was very similar to that of the prototype concrete pile since the unit weight of aluminium is 2700kg/m^3 compared with reinforced concrete which is usually assumed to be 2400kg/m^3

All of the piles were bored to a depth of 180mm, ensuring that a minimum 5D clear spacing existed below the toe of the pile, to minimize edge distance effects at the base of the model.

2.5. Sheet piled wall installation

Installation of the sheet pile enhancement to the bored piles was carried out as shown in Figure 5. The square plan foundations were manufactured from a continuous length of 0.8mm thick corrugated steel sheet which was folded and tack welded at one corner. This created a 50mm square inclusion around the central pile; equivalent to $2.5\text{m} \times 2.5\text{m}$ at prototype scale. The sheet pile inclusion was positioned concentrically about the model pile and embedded by gently tapped into position using a hand-held hammer as shown in Figure 4.

Two different sheet pile lengths were used, to investigate the impact of sheet pile embedment on the overall capacity enhancement provided by a composite foundation. The embedment depths of the sheet piled walls were 60mm and 120mm respectively, representative of 33% and 67% of the total rotary bored pile length; and equivalent to 3m and 6m respectively at prototype scale.

Following installation of the sheet piles, a resin pile cap was poured at soil surface level, simulating the pile cap that would be needed to provide a connection thereby allow the bored and sheet pile combination to act compositely under load. Small holes were drilled through the tops of the aluminium piles and sheet piles to allow steel wire to be passed through and then cast into the resin pile cap as a means of creating some physical connection between the piles and the sheet pile enhancement.

Whilst the reference pile was obviously not enhanced with embedded sheet piles a non-embedded sheet pile perimeter was placed at the soil surface to create a surface pile cap that was identical in plan dimensions to the embedded sheet piles. This is representative of the typical construction whereby a pile cap is used to transfer the structural loads into the foundation. Therefore, it is important to measure the realistic capacity of the pile

system where a pile cap may also provide an enhanced shallow foundation around the pile. Furthermore, constructing the pile cap ensured that any enhancement in axial capacity provided by embedding the sheet piled walls could be directly compared against the reference pile.



Figure 5 Installing the embedded sheet piled wall

2.6. Preparation of the model prior to loading

Upon completion of pile installation, any exposed soil surfaces were resealed with PlastiDip. The bored piles protruded above the level of the sheet piled walls and the area between the sheet piles and the bored pile was filled with Sika Biresin G27, (McNamara, 2001; Gorasia and McNamara, 2016) a fast cast polyurethane resin used commercially for intricate mouldings. This material has been used extensively in centrifuge model making at City, University of London owing to its low curing exotherm combined with low viscosity and rapid curing time (20minutes).

A machined aluminium loading cap was positioned centrally on top of each bored pile. Within each loading cap a centrally reamed countersunk bore was machined which allowed for a steel ball bearing to be placed. A force plate, comprising a series of three load cells sandwiched between two aluminium plates, was located over the piles to make contact with the ball bearing. This arrangement ensured that the piles were loaded axially, without any eccentricity, as shown in Figure 6.

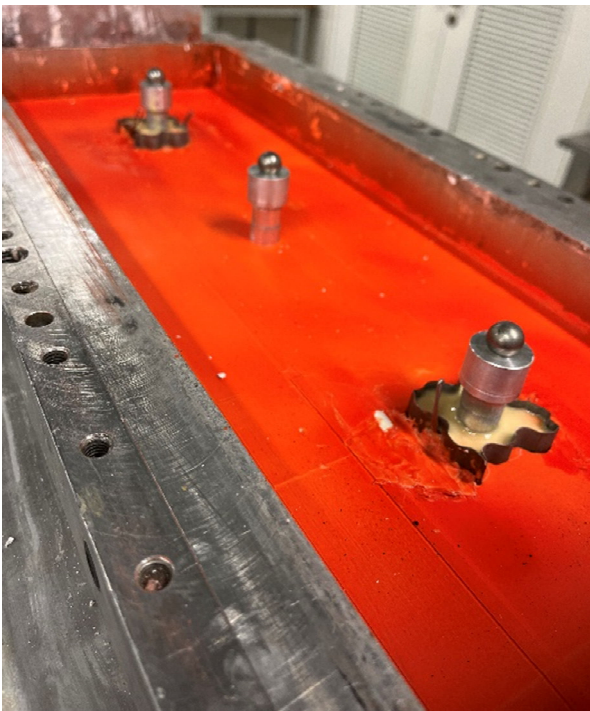

Figure 6 Foundations during model making (the surface pilecap is not shown on the central pile but was installed later)

3. Pile loading

Prior to loading the model was placed on the centrifuge and accelerated to 50g. Under normal circumstances the model would be connected to a standpipe to allow a water table to be established within the model. However, practical difficulties prevented this and there was consequently no period of consolidation. The loading phase was therefore carried out immediately after the centrifuge reached 50g.

The piles were loaded simultaneously through a single beam motorized actuator, at a rate of 1mm/minute. This apparatus is shown schematically in Figure 7. The beam is sufficiently stiff that it exhibits minimal deflection under the magnitude of load generated in the experiment thereby allowing all foundations to be loaded simultaneously.

Displacement of the foundations was determined from the measurement of time using the data logging computer. This was made possible owing to the known accuracy of the motor control system that drives the lead screw mechanism which includes an encoder that is capable of moving the motor at a precise and known speed. This allows the displacement to be determined with

sufficient accuracy for the purposes of this experiment without the use of LVDTs.

It was intended that the foundations should continue to be loaded until the load increase with time became negligible, suggesting that peak capacity had been reached. However, the sheet pile enhanced foundations exhibited such significant additional capacity that it was not possible to determine the ultimate capacity of these foundations with the travel available on the loading apparatus that had been used.

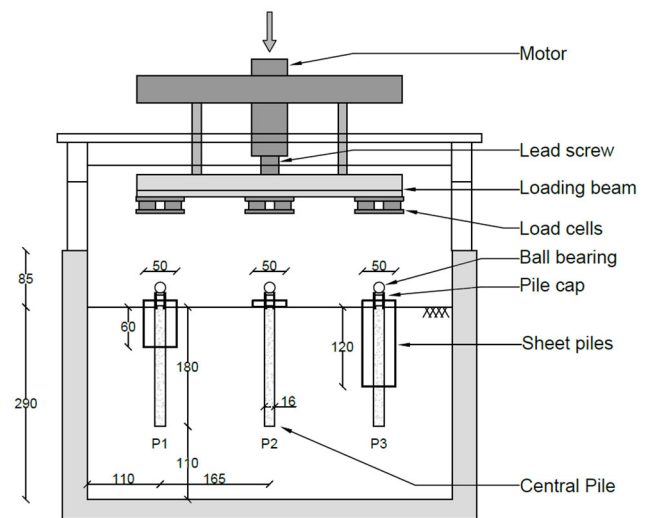

Figure 7 Arrangement of loading apparatus on model

4. Results

The load-settlement curves for each of the three model foundation tests are given in Figure 8.

In general, the load displacement curves for each of the tests follow an expected trend. During the test, the initial stiffness of the unenhanced pile was not recorded owing to bedding issues at the beginning of the loading cycle. This was a result of the displacement transducers not having been fully engaged with the loading plate, and subsequently this data is unavailable; as the test progressed the displacement transducers engaged with the loading plate and settlement data could be obtained. However, the enhanced foundations appeared to be similarly stiff during the early part of loading with the stiffness reducing after about 1mm of settlement. During further loading the composite bored and sheet piled wall foundations exhibited a somewhat stiffer response and this continued well beyond the failure load of the unenhanced foundation.

In addition, the baseline bored pile displays definitive failure at a load of approximately 600N and at a settlement of 3mm, beyond this the pile continues to fail in end bearing at constant load.

However, the composite sheet piled foundation arrangements proved to be capable of carrying significantly higher loads. In this test, even the short sheet piled wall enhanced foundation reached an applied load of 1100N as it began to fail; whilst the more deeply embedded sheet pile wall reached loads in excess of 1230N without overcoming the full pile resistance.

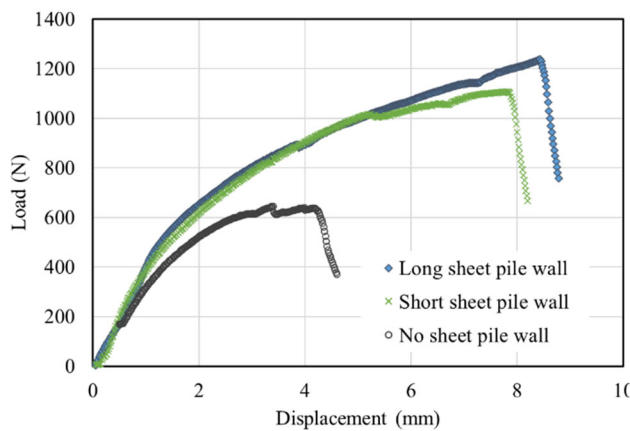

Figure 8 Load-settlement curves

5. Analysis

The ultimate bearing capacity of a foundation system is a sum of the shaft friction and end bearing, and described below. However, owing to the construction and installation method of the composite pile, the sheet piled foundation element is analysed using the ICP design method (Jardine et al., 2005) where the sheet piles are considered as open-ended tubular piles.

As such, the end bearing resistance mobilized by the sheet piled wall of the composite foundation is recommended to be reduced by a factor of two to account for plugging effects.

$$Q_{(ult)} = Q_b + Q_s \tag{1}$$

$$Q_s = EA_s Su \alpha \tag{2}$$

$$Q_b = EA_b (Nc Su + \gamma H) \tag{3}$$

$$Q_{b, sheet} = [EA_b (Nc Su + \gamma H)] / 2 \tag{4}$$

Su , the average soil undrained shear strength was measured using a hand shear vane immediately after each test and gave an average reading of 40kPa, the bearing capacity factor (Nc) was taken as 9 for deep piles, γ , bulk unit weight of 17kN/m³ was used, L is the pile length and α is the adhesion factor.

The ultimate bearing capacity of the plain foundation was calculated as a summation of the shaft friction of the pile and the bearing resistance of the shallow footing at ground level; with an estimated capacity of 640N.

In comparison, the foundations with both a bored pile and sheet piled wall take benefit from both foundation systems. For instance, the ultimate capacities of these piles have been derived by taking end bearing and shaft friction from the bore pile beneath the toe level of the sheet piled wall. In addition, the shaft friction of the full sheet piled wall is used, and the end bearing resistance of the wall system is reduced by half before being accounted for in the capacity of the system.

An estimate of each foundation system is summarized and presented in Table 1. It has been observed that using the equations above and the principle that both elements of the foundation system are in contact with the free proportion of the soil provide shear and bearing resistance to the pile.

The results demonstrate that the estimated foundation capacity, calculated using conventional pile capacity calculations and the ICP method accounting for a reduction of end bearing for a sheet piled wall system, gives a prediction that is within a 10% envelope of the measured ultimate capacity, as shown in Figure 9.

Note that the ultimate capacity of both composite sheet piled wall foundation systems were interpolated from the load settlement plots, owing to the fact that the piles had not failed during the centrifuge test.

	Pile only	Pile + 60mm sheet pile wall	Pile + 120mm sheet pile wall
Bored pile			
Ø (mm)	16	16	16
L (mm)	180	120	60
A _s (mm ²)	9048	6032	3016
A _b (mm ²)	201	201	201
Q _{s,pile} (N)	180	120	60
Q _{b,pile} (N)	73	73	73
Sheet pile			
B (mm)	-	50	50
D (mm)	-	50	50
L (mm)	-	60	120
A _s (mm ²)	-	14760	29520
A _b (mm ²)	-	3782	3782
Q _{s, sheet} (N)	-	295	590
Q _{b, sheet} (N)	390	680	680
Q_{ult} (N)	643	1168	1403

Table 1 Estimated capacities of the foundation systems

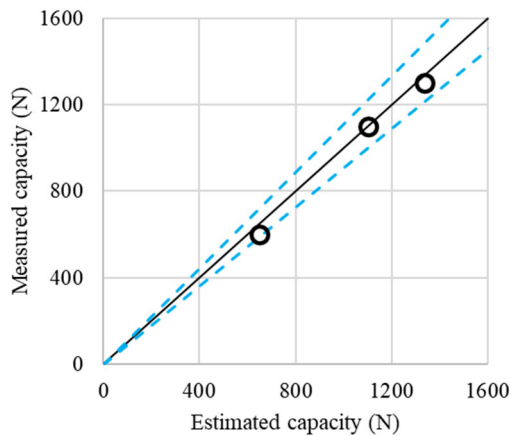

Figure 9 Comparison between estimate and measured capacities with a 10% margin

6. Discussion

The results from the centrifuge model pile load test demonstrate the potential benefit of providing a connection between rotary bored piles and a sheet piled wall to generate a composite acting piled foundation system. The data clearly suggests that forming a composite foundation could offer significant benefits over individual piles and it appears that the sheet piles do not need to be particularly deeply embedded to make a useful improvement in bearing capacity.

The exhumed foundations are shown in Figure 10. The connection between the central pile and pilecap remained intact suggesting the combined foundations worked in the manner intended.



Figure 10 Exhumed foundations after the test

The loading behaviour and bearing capacity of this composite foundation can be described by Jardine et al. (2005). This method describes the ICP design methods where the composite sheet piled foundations can be analysed as open-ended tubular piles, where end bearing resistance can be reduced by 50% to account for the plugging effect at the base of the pile, whilst the rest of the composite pile benefits from the additional shaft capacity afforded to the system by the sheet piled wall.

The influence of the sheet piled wall surrounding the bored pile contributes to the development of higher shear stresses along the length of the sheet piled wall as a result of the greater surface area. This in turn results in a higher

proportion of soil mobilization which results in a greater ultimate capacity of the composite pile system, furthermore the end-bearing capacity of a composite pile is increased as a result of the plugging effect at the base of the sheet piled wall, compared with the as-built end bearing resistance generated only from the solid bored pile. This behaviour is evident from the measured load bearing capacity of the long sheet piled wall, compared with the short sheet piled wall, and also compared against the pile without the sheet piled wall.

On full scale projects a settlement acceptance criteria is specified to achieve the necessary serviceability requirements on the scheme. Based on the results obtained from these tests, at 1% of the pile diameter the working load for each foundation solution are comparable, therefore the benefit under serviceability conditions is negligible. However, considering displacement at 10% of the pile diameter as the definition of pile failure, a significant improvement is realized when using the sheet piled wall system. The pile only foundation load at 10%D is 430N, whilst the sheet piled walls carry 515N and 575N respectively. This equates to a 27% average improvement in design capacity of the sheet piled wall foundation system.

7. Concluding remarks

Three model foundations in overconsolidated clay were loaded simultaneously at 50g in a centrifuge. Two of the foundations consisted of a central pile surrounded by sheet piles of differing embedment depth whilst the third had an enlarged pad at ground surface level. The use of sheet pile enhancements to the single pile foundations proved effective in increasing capacity at large strains and appear to show benefits at small strain.

Further experimental work is needed to demonstrate the efficacy of this method of enhancement since the benefits at small strain that could be reasonably expected were not especially apparent. At ultimate capacity even the shallow embedded sheet piles provide a significant increase in capacity suggesting that there may be merit in exploring this method further.

8. Acknowledgements

The authors acknowledge the assistance of the International Press-In Association in inspiring this research.

References

- Jardine, R., Chow, F., Overy, R. and Standing, J. 2005. 4 Design Methods for Piles in Clay. ICP design methods for driven piles in sands and clays. January 2005, Thomas Telford, London, pp28-37.
- McNamara AM (2001). Influence of Heave Reducing Piles on Ground Movements Around Excavations. PhD thesis, City University, London, UK.
- Gorasia RJ & McNamara AM (2016). High-capacity ribbed pile foundations. Proceedings of the Institution of Civil Engineers: Geotechnical Engineering, 169(3), 264–275. doi: 10.1680/jgeen.15.00073
- Panchal, J. P., McNamara, A. M., Goodey, R. J. (2018). Influence of geometry on the bearing capacity of sheet piled foundations. Proceedings of the 9th International Conference on Physical Modelling in Geotechnics (ICPMG 2018), July 17-20, 2018, London, United Kingdom, pp. 1395-1400.
- Yamaguchi, H., 1984. Chapter 7, stability analysis of soil structures, in *Soil Mechanics*, 3rd ed., pp. 197-223, Gihodo (in Japanese).