

The Press-in Method with Augering - Augering Area in Relation to Retaining Wall Design-

Tsunenobu NOZAKI

General Manager, International Construction Design & Planning Department, Giken Ltd., Tokyo, Japan

Email: nozaki@giken.com

ABSTRACT

When retaining walls are designed, design parameters of undisturbed soil are normally used. In reality, if the retaining wall is comprised of piles, they are often installed assisted by ancillary equipment, such as water jetting or augering, to reduce installation resistance. To what extent the impact of these ancillary methods have on the soil and effect the retaining wall design is not known.

This report features impacts of driving assistance of pile installation on retaining wall design. A project in the UK was used as a case study to observe if the design of a cantilevered retaining wall is still satisfied, despite a local ground disturbance by augering in the case of cohesive soil.

Key words: *Press-in Method, Retaining Wall, Chalk*

1. Outline of the project

1.1. Place

Erith is a town in south-east London in the London Borough of Bexley. The town is located to the north-east of Bexleyheath and north-west of Dartford and lies on the south bank of the River Thames.

1.2. Background and objectives of the project

The site was previously used as a warehouse which covered the central and southern part of the site. The front and northern parts were concrete hardstanding. It was proposed to develop some area of the site with flats of 5 storey height and of lightweight steel-frame construction.

2. Structural type and piling method

2.1. Site condition

The site is located close to the south bank of the River Thames as shown in **Fig. 1**. The surface of the site was open ground sloping gradually down from West Street, with a steep slope of made ground on the north-western boundary adjacent to private residential properties. The steep slope is approximately 5m to 6.5m higher than the site. It was proposed to build a retaining wall on the slope shoulder for the construction of a car park.

The section adjacent to house No 3 has a concrete retaining wall, which gives way to a short brick and cobble retained section at the southern end, adjacent to a garden. The remainder of the central and southern section comprises mainly a very steep unsupported slope, overgrown with vegetation but with some zones of bare soil.

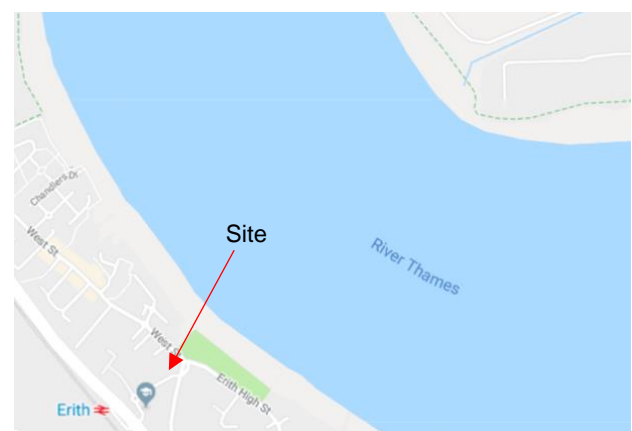

Fig. 1 Site Location Map

2.2. Ground condition

The basic soil makeup is Thanet Sand overlying Upper Chalk. The site investigation report revealed quite deep made ground incorporating an old buried unreinforced concrete slab, extending to between 1.55m and 2.4m at the southern extent of the proposed building. Progressing northwards, the made ground is less thick. At its thickest part, there was a significant proportion of loose grey/brown silty sandy clayey soil with frequent brick and concrete rubble. There were also layers of brick rubble. Progressing northwards, the thinner made ground tended to be more stable.

Each trial pit revealed a chalk layer beneath the made ground. Within the southern and central area, there was an upper zone of highly weathered weak chalk comprising intact flint fragments and chalk fines. This structureless material is visually borderline and variable between Grade Dm and Dc (matrix or clast dominant). However, being just at or above the water table, it was in a very poor state when excavated.

The underlying chalk, which was met at each point, comprises intact blocky chalk, a structured intact hard chalk with some fines. Once met, it proved to be relatively difficult to excavate by mechanical excavator. The laboratory tests have shown this to be a high to very high dense chalk.

Ground water inflows assessed as “medium to fast” were met in the most southern trial pits in the lowest ground at 2.15m to 2.6m depth, at or just above the top of the hard chalk. There was no rise in the water level at this time of year (April). At the time, the tide was low in the Thames.

The following values in **Table 1** are suggested for preliminary design of retention structures: -

Table 1. Preliminary Design Values

	Bulk Density (kg/m ³)	Effective Cohesion (kN/m ²)	Effective Friction Angle (degrees)
Thanet Sand to 1.3/1.5m depth	1800	ZERO	33
Thanet Sand to +4.75m	1900	ZERO	36
Hard Chalk	2000	20	40

The typical borehole log is shown in **Fig. 2** with the sheet pile elevation.

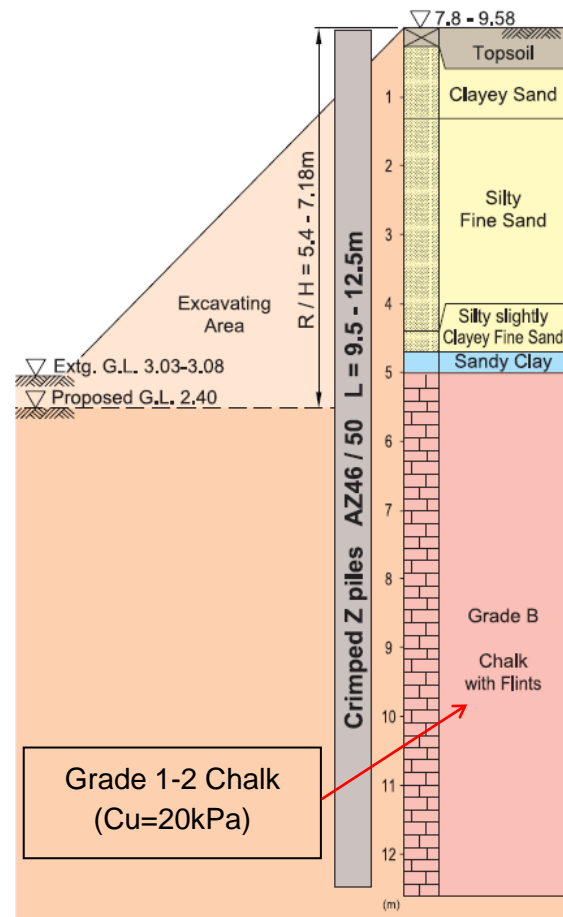

Fig. 2 Typical Borehole Log

2.3. Structural type

The Project was to supply and install a sheet pile retaining wall, to support adjacent ground, and to allow the construction of a car park serving the site development. After excavation the wall eventually stood in cantilever, and was likely to deflect approximately 40mm at the top. Giken Ltd. proposed that in order to compensate for this deflection, they install the piles off plumb, while still ensuring that the wall was positioned precisely. Giken's engineers were consulted on this design before work commenced.

The permanent retaining wall was built with 9.5m to 12.5m long crimped pairs of AZ46 and AZ50 sheet piles. They were installed to form a cantilevered retaining wall with the retained height of 5.4m to 7.18m. The retaining wall was finished off with a wooden clad for aesthetic reasons as shown in **Photo 1**.



Photo 1. Completion with a Wooden Clad

2.4. Piling method

In order to install sheet piles through both the rubbly made ground and reasonably stiff chalk, the Press-in with simultaneous augering was utilized. As the retaining wall was installed close to the boundary line on a sloping embankment, the passive side of the retaining wall was augered during the pile installation to cope with spoils from the augering. **Photo 2** shows the auger set up at the passive side.



Photo 2. Piling Work in Progress

3. Press-in piling

3.1. Layout

The sheet pile configurations are shown in **Fig. 3**, **Fig. 4** and **Fig. 5**.

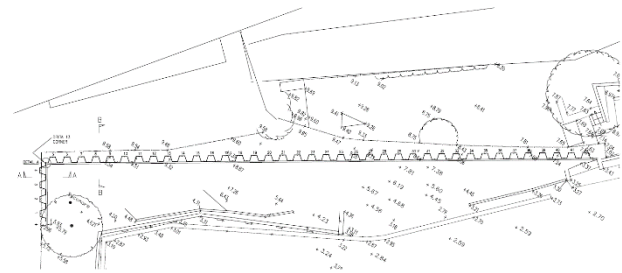

Fig. 3 Plan View Layout

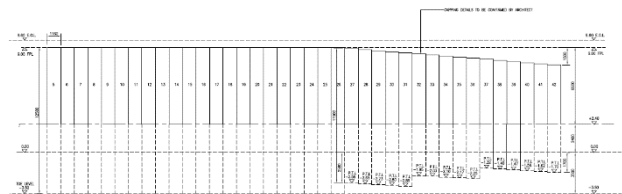

Fig. 4 Elevation

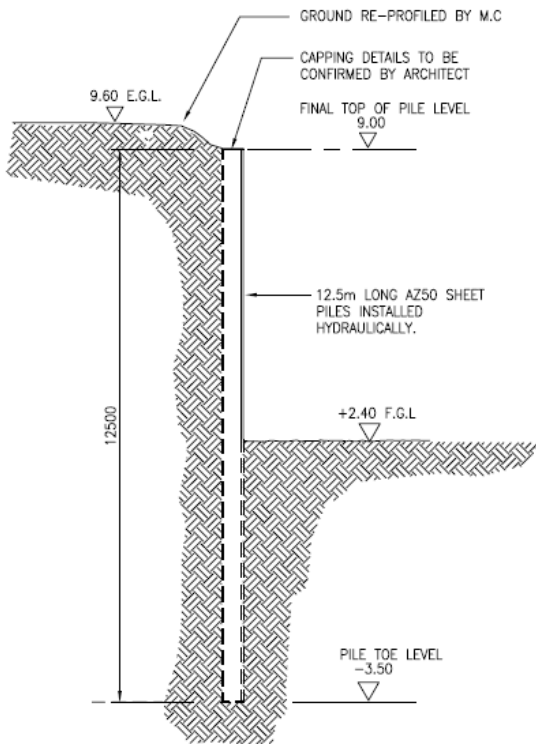

Fig. 5 Cross Section

3.2. Productivity

The piling work was carried out from November to December in 2005 by utilizing the Silent Piler SCZ675WM with the Pile Auger. The typical production rate was approximately 100m a day of total pile driving length, which is equivalent to 116m² of wall area.

3.3. Encountered difficulties

On the project, minimizing lateral deflection of the retaining wall during excavation was critical, due to the presence of adjacent private properties. Therefore, in terms of lateral deflection of the retaining wall, it was ideal to position the auger on the active side to minimize ground disturbance on the passive side. At the same time, it was also necessary to avoid disturbing the active side, to minimize ground displacement on that side. Furthermore, it was not practical to temporarily deposit and backfill arisings from the augering on the active side.

After discussing issues of the effect on the retaining wall design and wall integrity, a cantilevered Z sheet pile retaining wall was installed utilizing augering on the passive side. In order to minimize the lateral deflection of

the retaining wall, a flight narrower than the pile width was utilized. This left some undisturbed area within the wall profile as described in Fig. 6.

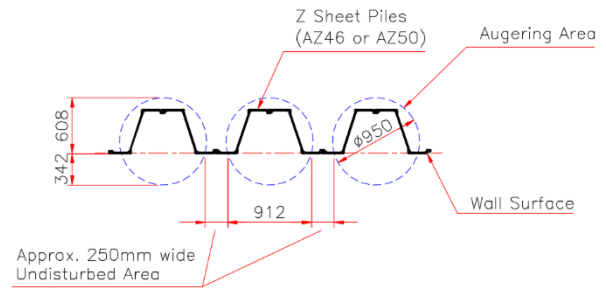

Fig. 6 Augering Area

4. Additional data

After each pile installation, the area disturbed by augering was backfilled with augering spoils. After pile installation, the lateral deflection of the retaining wall was continuously monitored through to the project completion.

Despite the augering on the passive side, the deflection at the top of the retaining wall was only 30mm or less, while the design deflection is estimated at 44.7mm.

Photo 3 shows post excavation.



Photo 3. Post Excavation

5. Design consideration

This report reveals that the augering method was effectively used to overcome difficult ground conditions. At the same time, the retaining wall design requirement was met, despite the ground disturbance as a consequence of the augering. It is thought that the following aspects may have contributed to achieving the design requirement.

1) Ground-arch effect

When a retaining wall is loaded laterally, distribution of the soil stress can be simulated based on the Theory of Elasticity using the Boussinesq equation that considers a point load on the surface of a semi-infinite, homogeneous, isotropic, weightless, elastic half-space. The concept of the soil arch effect prepared from the Boussinesq's equation by Bowles [1996], as shown in Fig. 7.

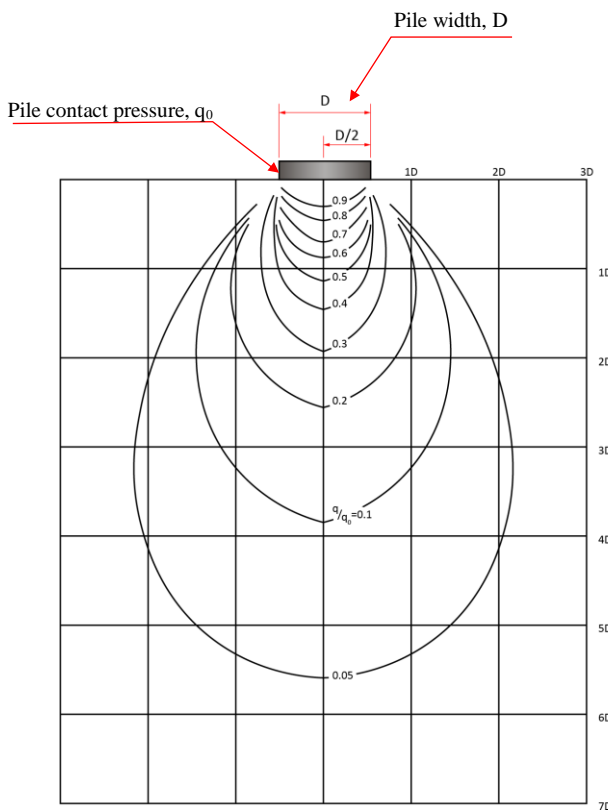

Fig. 7 Pressure distribution formed on the passive side of a pile, showing the intensity of pressure q/q_0 , based on the Boussinesq equation (after Bowles [1996])

On the project, the piles were installed with augering, leaving an approximately 250mm of undisturbed area between adjacent piles. It was concluded that the lateral earth pressure loaded on the disturbed area was radially transferred to the passive soil. This gave an effective passive area wider than the 250mm as shown in Fig. 8.

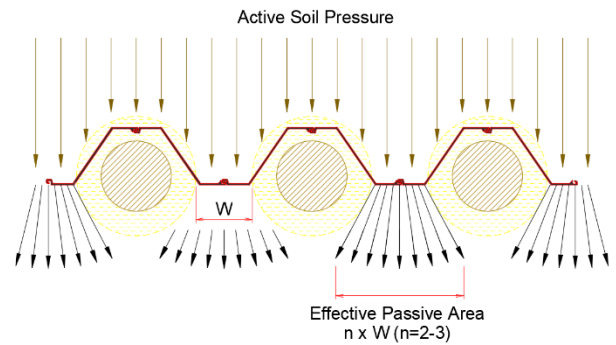

Fig. 8 Effective passive area

The effective passive area is described as follows: -

Effective passive area = nW

n : Passive mobilisation factor

W : Undisturbed area on pile surface

In general, a passive mobilisation factor of 2-3 is used depending on soil conditions. There is no simple relationship between the characteristics of the effective passive area (nW) and soil conditions, because any relationship is dependent on the pile size and on the nature and sequence of the strata. " nW " at a certain distance (H) in low strength cohesive soil is generally greater than that in dense cohesion less soil.

2) Confined effect of disturbed soil

After pile installation, the auger is extracted and the augering spoils are backfilled. In general, the strength of the backfill is ignored for retaining wall design, due to its uncertainty as a result of disturbance. However, the augered areas are not left void, but are filled with augering spoils. As such, the augered areas are sufficiently confined and the backfill should transfer the active earth pressure to the surrounding undisturbed soil to some extent. It is thought that this "confined effect" contributed to a lateral deflection, which is smaller than the design deflection. However, this effect is not covered in this report, and the following aspects should be observed if checking this issue at another point in time.

- a) Measuring density or stiffness of backfill
- b) Measuring shear strength of backfill
- c) Measuring compressibility of backfill

- d) Measuring stress on pile surface on passive side
- e) Measuring stress on surface of undisturbed soil on passive side
- f) Measuring lateral deflection of retaining wall
- g) Making speculation on linking above aspects.

6. Concluding remarks

When augering is required to install retaining walls, it is prudent to give retaining wall design careful consideration to this aspect, especially if the retaining wall is a cantilevered wall. This is because the impact on the soil parameters by augering is not scientifically ascertained and it is difficult to evaluate characteristics of the disturbed soil. Therefore, augering may cause unexpected large horizontal deflections of retaining walls if an overoptimistic retaining wall design is used. On the other hand, if over pessimistic retaining wall design is used, unnecessary remedial works, such as grouting or the like, may be required to stabilize the retaining wall. This will make retaining wall construction less economical.

Unless retaining walls are installed with a complete underreamed auger (larger auger diameter than the pile width), there are some undisturbed areas on the retaining wall surface, which have decent horizontal passive strength for the retaining wall. Based on this, the retaining wall can be designed with a reasonable passive mobilization factor, which determines the effective passive area. With this approach, retaining walls can be designed rather economically, avoiding overestimated/underestimated design.

References

Bowles, J.E. 1996. *Foundation Analysis and Design*. 5th edition, McGraw-Hill, Singapore.